



Pneumatic and Cushion Forklift Trucks

D35S / D40S / D45S-5 & D50C / D55C-5
 D40SC / D45SC / D50SC-5 / D55SC-5
 G35S / G40S / G45S-5 & G50C / G55C-5
 G40SC / G45SC / G50SC-5 / G55SC-5
 GC35S / GC40S / GC45S-5 & GC50C / GC55C-5
 3,500kg to 5,500kg Capacity

PRO5
SERIES

PRO5
SERIES



GC35S / GC40S / GC45S-5
 GC50C / GC55C-5
 3,500kg 4,000kg 4,500kg
 5,000kg 5,500kg
 Cushion Tire



D35S / D40S / D45S-5 & D50C / D55C-5
 G35S / G40S / G45S-5 & G50C / G55C-5
 G40SC / G45SC / G50SC-5
 D40SC / D45SC / D50SC-5
 3,500kg 4,000kg 4,500kg 5,000kg 5,500kg
 Pneumatic Tire

NEW
EPA Tier-3 &
Stage-3A



PSC0807B3 (June.2011)



Head Office : 7-11, Hwasu-Dong, Dong-Gu, Incheon, Korea.
 Seoul Office : 22nd floor, Doosan Tower Bldg, Euljiro 6-Ga
 Jung-Gu, Seoul, Korea.
 Tel : 82-2-3398-8632 Fax : 82-2-3398-8619

AUTHORIZED DEALER



Product and specifications are subject to improvement and change without notice.

***Field Proven and Endurance Tested...
To Give You the Best Forklift Value on
the Market.***

That's what Doosan has put into the design, development and production of the D/G/GC45S-5 series, to provide customers with:



- ✓ *Optimized Operator Comfort & Safety*
- ✓ *Proven and Durable Components*
- ✓ *High Powered and Fuel efficient Diesel and LPG Engines for High Performance including*
 - *Low Emissions and Minimal Vibration*
- ✓ *Enhanced Maintenance and Serviceability*
- ✓ *Virtually Maintenance-free Oil Cooled Disc Brakes*
- ✓ *2 Speed Autoshift Transmission*
- ✓ *Lift and Tilt Locking Hydraulic Control Valve*
- ✓ *OSS(Operator Sensing System)*
- ✓ *A Variety of Operator Friendly Features*

Operator Comfort and Driver Efficiency is One of Doosan's Top Priorities



Doosan forklifts are designed to keep your operation and operators running at peak efficiency. Enhanced comfort features ensures operators do not experience fatigue or strain during everyday operation.

Designed to be simple, and easily adjusted, this operator compartment will make your driver feel right at home.

● High Visibility Overhead Guard and Front-end

Wider mast window, repositioned hydraulic hoses and flat bar style overhead guard optimizes operator sight lines forward, up and to the load.



● Integrated Instrument Panel

The centralized and easy-to-read instrument panel maximizes operator efficiency. Fuel gauge, engine hour meter, engine oil pressure, coolant and transmission temperature, mast interlock, transmission neutral, seat belt, brake oil level indicator keeps operator ever aware of all vehicle performance systems.



● Convenience Tray

Easily handles refreshments, paperwork, small tools, etc for operator efficiency.



● Auto Tilt Leveling (Optional)

Easily returns mast to upright vertical position with the simple push of a button



● Deluxe Suspension Seat with OSS (Operator Sensing System)

A comfortable deluxe suspension seat with OSS(Operator Sensing System), a large seatback angle, longer seat travel length and operator's weight resistance on front side allow multiple adjustments for optimum seating comfort.

- ✓ Parking alarm
- ✓ Seat belt indicator
- ✓ Neutral shift feature



● Spacious Operator compartment

Wide open operator leg room, stepless tiltable steering column and ergonomically located operator pedals with a low cowl height facilitate ease of operation.



● Optimum Pedal System(OPS)

This Option Pedal System will reduce the operators fatigue and provide best sense of drivability. Especially, the new electronic accelerator will provide the operator with secure and exact speed control.



Minimized Maintenance, Easy Serviceability.



Doosan's Goal is to Make Your Material Handling Organization as Efficient and Reliable as Possible, by minimizing Down Time to Reduce Overall Maintenance Cost.

● Oil- Cooled Disc Brakes(ODB)

Oil cooled disc brakes are available as an option on all D,G(C)45S-5 series pneumatic and cushion forklifts and are especially recommended for applications in humid, abrasive or corrosive environments, or with ramp, loading and unloading applications. This enclosed brake system eliminates outside contamination, significantly extending brake life and decreasing maintenance costs. Oil cooled disc brakes have service intervals 5 times longer than conventional shoe brakes, and require little to no maintenance.

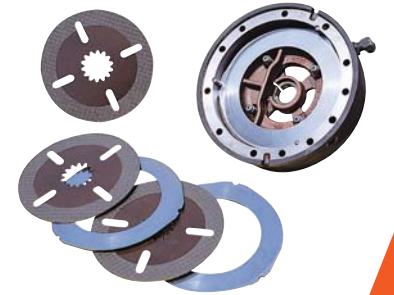

● Power Reversal Transmission

Top mounted control valve on the transmission precisely modulates clutch oil pressure for smooth forward / reverse directional changes, permitting on-the-go shifting up to 5mph.



● Hydrostatic Steering System

- No mechanical connections between steering wheel and steer axle for reduced maintenance.
- Easy Access grease fittings for proper lubrication.
- Sealed tapered roller bearings offer protection against contamination and in high impact applications.
- Provides low effort steering with quick steering response.



● Air Cleaner

A large capacity, dual element air cleaner permits long service intervals. The primary filter can be washed and re-used up to 5 times. A high air intake on the overhead guard is standard, and aids in drawing clean, cool air into the engine intake system.



● Full Floating Drive Axle

Strong one-piece cast housing keeps axle components aligned. High tensile strength alloy steel axle shafts extends axle life while splined side gear & drive wheel hub gears transmit high torque to the drive wheels.



● Tool - less Side Cover and Floor Plate facilitates Serviceability



● Integration of Electrical Components for Easy Maintenance

Fuse and relay box located in front of the engine simplifies servicing

A Hallmark of Durability and Reliability



NEW
EPA Tier-3 &
Stage-3A

High powered and fuel - efficient diesel and LPG engines provide high performance levels and insure long term power plant efficiency.

- **Doosan Infracore DB58S (68kW)**

This powerful 6-cylinder 5.8L diesel engine delivers excellent power to meet the needs of the most demanding applications. DB58S diesel engines comply with EPA emission regulations.

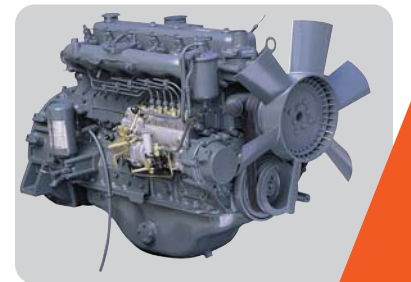

- **GM V6 4.3L (69kW)**

The well known, field proven GM 4.3L LP Gas engine has excellent durability. Its low noise and minimal vibration features add to operator's comfort while the engine provides the forklift with excellent power.

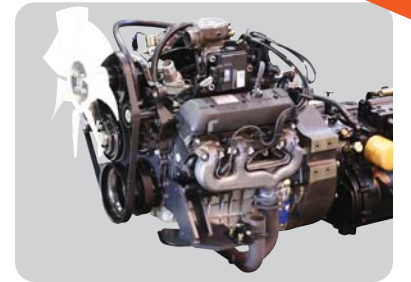

- **D439E 3.9L (68kW)**

This 3.9 Liters Common Rail turbo-intercooler (air cooler) Diesel engine complies with EPA Tier III and Stage-3A emission regulation. The electric governed engine control system provides high performance and supplies easy diagnostic system. Four cylinders, Common Rail Direct Injection, full range electrical governor and a heavy duty fuel filter with water separator, all add up to a powerful and efficient power plant which keeps its strong performance even in high altitude working environments.



DRIVE THE DIFFERENCE...

DRIVE DOOSAN !

**Proven Quality,
Responsive Service and
A Reliable Partner...**

After sales service of Doosan forklifts is available from your authorized local dealers backed by Doosan's own customer service center. And Doosan provides 100% parts inventory to insure any downtime is minimized. When you own a Doosan forklift, our high quality, responsive customer support team comes with it.

The Doosan network starts with your local dealer and ends with a national team of highly qualified and experienced personnel standing ready to support all your material handling needs.

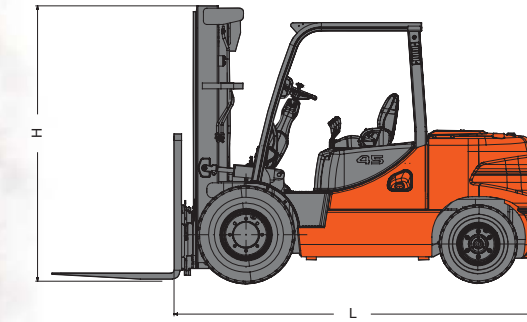
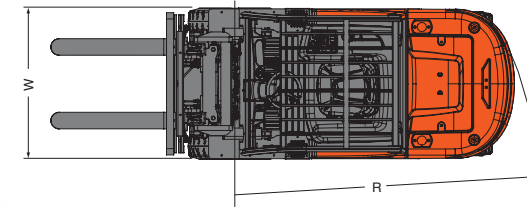

Option Availability

Options	● : Standard ○ : Optional		
	D35/D40/D45S-5 & D50/D55C-5 D45C / G45C / D45C / D55C-5	G35 / G40 / G45S-5 & G50 / G55C-5 G40C / G45C / G50C / G55C-5	G35S / G40S / G45S-5 & G50S / G55C-5 G40C / G45C / G50C / G55C-5
Fuel Cap with Key	○	n/a	n/a
Precleaner	○	○	n/a
Vertical Exhaust Tube	●	○	n/a
Catalytic Muffler*	○	○	●
Modular Operator Cabin Type A/B/C	○	○	n/a
Full Operator Cabin Type B	○	○	○
Air Conditioner	○	n/a	n/a
Non Marking Tire(Solid)	○	○	○
Spark Arrestor(w/o Cabin)	○	n/a	n/a
Mono Ped Foot Direction and Acceleration Control	○	○	n/a
AutoShift (Single,Dual Tire)	○	○	○
Engine Shutdown	○	●	●
Swingdown LP MTG	n/a	○	○
Lift and Tilt Locking Hydraulic Control Valve	●	●	●
Auto Tilt Leveling	○	○	n/a
Rear Grab Bar with Horn	○	○	○
Hydraulic Accumulator	○	○	○
Integral Side Shifting Fork Positioner	○	○	○
Hook on Sideshifter	○	○	○
UL LPS,DS Rating	○	○	○

* Catalytic muffler is standard for Tier-3 E/G only

Main Specification

Sales Model		D35S-5	D40S-5	D45S-5	D50C-5	D55C-5			
Rated Load Capacity	kg	3,500	4,000	4,500	5,000	5,500			
Load Center	mm	600	600	600	600	600			
Overall Length to Fork Face	L mm	3,100	3,151	3,265	3,300	3,350			
Truck Overall Width	W mm	1,372	1,451	1,451	1,451	1,451			
Height of Overhead Guard	H mm	2,225	2,230	2,230	2,280	2,280			
Minimum Turning Radius	R mm	2,770	2,820	2,865	2,930	2,990			
Travel Speed, Loaded	km/h	24	24	24	24	24			
Lifting Speed, Loaded	mm/s	520	540	520	530	470	525	470	520
Wheel Base	mm	2,000	2,000	2,100	2,100	2,100			
Engine Models		DB58S	D439E	DB58S	D439E	DB58S	D439E	DB58S	D439E
Rated Power of Engine	kW/rpm	68 / 2,200	68 / 2,300	68 / 2,200	68 / 2,300	68 / 2,200	68 / 2,300	68 / 2,200	68 / 2,300
Max Torque	N-m/rpm	324 / 1,600	324 / 1,600	324 / 1,600	324 / 1,600	324 / 1,600	324 / 1,600	324 / 1,600	324 / 1,600
Cylinders / Displacements	cc	6 / 5,785	4 / 3,900	6 / 5,785	4 / 3,900	6 / 5,785	4 / 3,900	6 / 5,785	4 / 3,900

Sales Model		G35S-5	G40S-5	G45S-5	G50C-5	G55C-5
Rated Load Capacity	kg	3,500	4,000	4,500	5,000	5,500
Load Center	mm	600	600	600	600	600
Overall Length to Fork Face	L mm	3,100	3,150	3,265	3,300	3,350
Truck Overall Width	W mm	1,372	1,451	1,451	1,451	1,451
Height of Overhead Guard	H mm	2,225	2,230	2,230	2,230	2,230
Minimum Turning Radius	R mm	2,770	2,820	2,865	2,930	2,990
Travel Speed, Loaded	km/h	20	19.5	19.5	19.5	19.5
Lifting Speed, Loaded	mm/s	500	500	500	490	470
Wheel Base	mm	2,000	2,000	2,100	2,100	2,100
Engine Models		G643(E)	G643(E)	G643(E)	G643(E)	G643(E)
Rated Power of Engine	kW/rpm	70/2,500	70/2,500	70/2,500	70/2,500	70/2,500
Max Torque	kgf.m/rpm	31/1,500	31/1,500	31/1,500	31/1,500	31/1,500
Cylinders / Displacements	cc	6 / 4,294	6 / 4,294	6 / 4,294	6 / 4,294	6 / 4,294

Sales Model		GC35S-5	GC40S-5	GC45S-5	GC50C-5	GC55C-5
Rated Load Capacity	kg	3,500	4,000	4,500	5,000	5,500
Load Center	mm	500	500	600	600	600
Overall Length to Fork Face	L mm	2,682	2,686	2,828	2,878	3,010
Truck Overall Width	W mm	1,270	1,270	1,420	1,420	1,420
Height of Overhead Guard	H mm	2,155	2,155	2,155	2,155	2,155
Minimum Turning Radius	R mm	2,360	2,400	2,530	2,580	2,630
Travel Speed, Loaded	km/h	18/19	18/19	21/22	21/22	21/22
Lifting Speed, Loaded	mm/s	500/550	480/550	480/550	450/500	450/500
Wheel Base	mm	1,630	1,630	1,790	1,790	1,790
Engine Models		G643(E)	G643(E)	G643(E)	G643(E)	G643(E)
Rated Power of Engine	kW/rpm	70/2,500	70/2,500	70/2,500	70/2,500	70/2,500
Max Torque	kgf.m/rpm	31/1,500	31/1,500	31/1,500	31/1,500	31/1,500
Cylinders / Displacements	cc	6 / 4,294	6 / 4,294	6 / 4,294	6 / 4,294	6 / 4,294

DRIVE THE DIFFERENCE...

DRIVE DOOSAN !