



Doosan Infracore  
Forklift

## Pneumatic Diesel Forklift Trucks 11,000kg to 16,000kg Capacity

**PRO5**  
SERIES

D110  
D130  
D160

**PRO5**  
SERIES



**D110 / 130 / 160S-5**  
11,000 kg , 13,000 kg , 16,000 kg  
Diesel , Pneumatic Tire



Printed in Republic of Korea PSC2604B0(Sep.2006)

**DOOSAN** Doosan Infracore  
Forklift

Head Office : 7-11, Hwasu-Dong, Dong-Gu, Incheon, Korea.  
Tel : 82-32-211-5011 Fax : 82-32-211-5412  
Seoul Office : 22nd floor, Doosan Tower Bldg, Euljiro 6-Ga  
Jung-Gu, Seoul, Korea.  
Tel : 82-2-3398-8630 Fax : 82-2-3398-8619  
Web site : <http://iv.doosaninfracore.co.kr/eng>

AUTHORIZED DEALER

Product and specifications are subject to improvement and change without notice.



## ***TOUGH, PRODUCTIVE AND GOOD LOOKIN' TO !***

That's the complete package you'll get with our new D110-D160 pneumatic family.

The Doosan design team has pulled out all the stops to give customers the most **ROBUST** and **DURABLE** machines in our forklift product line-up.

These powerful pneumatics with their **INCREASED CAPACITY** can handle the toughest tasks in the most demanding applications with **SPEED, POWER** and **EFFICIENCY**.



- Powerful and Efficient Intercooler Turbo-charged Doosan DL06 Diesel Engine
  - 140 PS(138HP) for D110/130
  - 160 PS(158HP) for D160
- Full Air Actuated Brake System
  - Service Brake
  - Parking Brake
- Integrated Operator Instrument Panel
- Pilot Actuated Hydraulic Control Valve and Levers
- Low Emission Tier III Engine
- Optional Tiltable Operator Compartment with or without Cab
- Electrically Controlled Full Autoshift Transmission
- Rugged Planetary Drive Axle



## **OPERATORS ON THE JOB WILL FEEL RIGHT AT HOME**

### **..... THANKS TO ALL THE COMFORT AND CONVENIENCE FEATURES IN OUR HUMAN ENGINEERED OPERATOR COMPARTMENT**

D110/130/160S-5 series comes equipped with our optimized operator comfort systems. The combination of a spacious operator compartment with a variety of operational enhancements will boost productivity in any application. Operators can efficiently control and monitor the truck operational status at a glance from their seated position.

#### **Operator friendly features include:**

- **Spacious Operator compartment**

Wide operator leg room, tiltable steering column and ergonomically located operator pedals with a low cowl height facilitate ease of operation.

- **Optional Deluxe Operator Cab**

The all round visibility and deluxe operator cab is newly designed for maximum comfort of climate control.

Highly visible front, top glass, side slide windows and numerous options will make operators feel right at home on the job.

- **Deluxe Suspension Seat**

Full suspension deluxe seat with 6 directional adjustments keeps operators fresh and productive throughout the shift.

- **Integrated Instrument Panel**

The centralized and integrated easy-to-read instrument panel maximizes operator efficiency. Fuel gauge, engine hour meter, air pressure gauge, engine oil pressure, coolant and transmission temperature gauge keeps operator aware of all vehicle performance systems

- **Pilot Actuated Hydraulic Control Valve and levers**

with minimal valve throw provides smooth and responsive hydraulics for superb operator control.

- **Wide Foot Steps and Grab Bar**

Wide and large open foot steps with anti-skid surface and a conveniently positioned overhead guard pillar grab bar provide effortless entry and exit.

- **Built in Air conditioning Duct and Grills (with Optional Operator Cab)**

are operator friendly positioned for maximum comfort in any environment.





**MINIMIZED MAINTENANCE,  
EASY SERVICEABILITY!**

**A HALLMARK OF DURABILITY, RELIABILITY AND  
SERVICEABILITY**

Doosan forklift trucks are designed with longevity in mind. A Doosan truck has specific design elements that enhance the reliability of its parts for decreased wear and tear and increased endurance. Count on the reliability of a Doosan forklift truck for peace of mind allowing you to concentrate on aspects of your business besides material handling

● **A Planetary Type Drive Axle**

Planetary drive axle assembly with steel housing features hardened load-bearing spindles and full-floating axle shafts with positive oil flow to all gears and bearings, four-pinion, hypoid differential and radically floating sun and ring gear.



● **Pre-Cleaner and Dual Element Air Cleaner**

Heavy duty air cleaning system extend engine service life and allows clean, cool air into the engine intake system.



● **Optional Side Tiltable Operator Compartment and Tiltable Operator Cab**

makes servicing of all powertrain components quick and easy. An electrically assisted hydraulic actuated cylinder tilts operator compartment to left side about 65 degrees for easy access to inside truck components



one touch tilting cabin switch

**PRODUCTIVITY COMES STANDARD**



**TOUGH, PROVEN AND RELIABLE COMPONENTS....  
GUARANTEE EFFICIENT AND PRODUCTIVE OPERATION**



**WE'VE COMBINED POWER WITH EFFICIENCY TO  
GIVE YOU THE MOST PRODUCTIVE TRUCK IN THIS  
PRODUCT RANGE.**

● **Low emission, High power and Fuel Efficient 5.9 Liter Diesel Engine**

Doosan DL06 turbo-intercooler (air cooler) diesel engine complies with EPA Tier III and Euro Stage 3 emission regulations. The electric governed engine control system provides high performance and low fuel consumption rates for excellent economical operation. Six cylinders, Common Rail Direct Injection, full range electrical governor and a heavy duty fuel filter with water separator, all add up to a powerful and efficient power plant.



● **Fully Electric controlled Autoshift Transmission**

provides electronic inching enabling even massive loads to be moved with great precision. Fully capable of shifting under power, soft gear shifting is achieved with 3 forward and 3 reverse gears. Maintenance requirements and service life are greatly enhanced.



● **Hydraulic Motor Driven Remote Cooling Fan**

A large capacity cooling fan driven by a remote hydraulic motor effectively manages operating temperatures to enhance engine wear and productive capacity.



**PRODUCTIVITY COMES STANDARD**

**DRIVE DOOSAN !**



**PROVEN QUALITY,  
RESPONSIVE SERVICE AND  
A RELIABLE PARTNER....**

Doosan's goal is to make your material handling operations as efficient and reliable as possible.

After sales servicing of Doosan forklift trucks is available from both the selling dealership and Doosan's own customer service center. And Doosan provides 100% parts inventory to insure any downtime is minimized.

When you own a Doosan forklift truck, our high quality, responsive customer support team comes with it.

The Doosan network starts with your local dealer and ends with a national team of highly qualified and experienced personnel standing ready to support all your material handling needs.

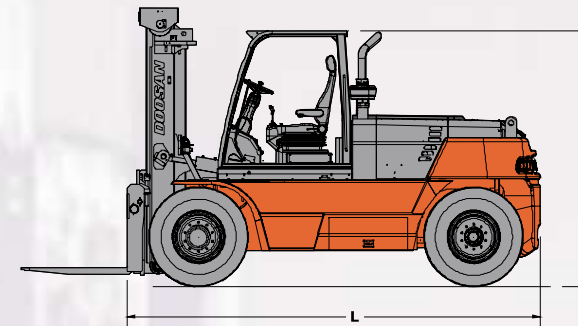
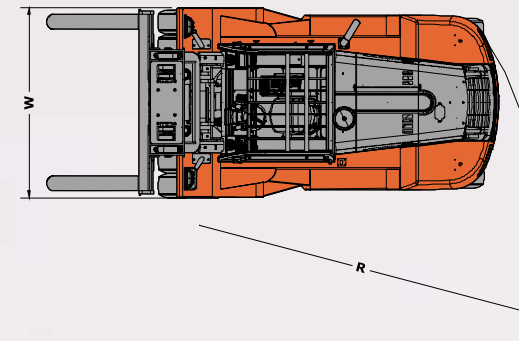

■ **Option Availability**

Options	D110S-5	D130S-5	D160S-5
2 Section Valves (Pilot Operated)	●	●	●
3 Section Valves (Pilot Operated)	○	○	○
4 Section Valves (Pilot Operated)	○	○	○
5 Section Valves (Pilot Operated)	○	○	○
Deluxe Suspension Seat- Vinyl	●	●	●
Deluxe Suspension Seat- Cloth*	○	○	○
Tilttable Operator Cab	○	○	○
Air Conditioner / Heater	○	○	○
Sound Suppression Package	○	○	○
CD Player & Radio for Cabin	○	○	○
2 Rear Working Lights	○	○	○
4 Working Lights	○	○	○
2 Front Lights on Fender	○	○	○
Rear Strobe Lamp	○	○	○
Spark Arrestor	○	○	○
Tool	●	●	●
Solid Soft Tires	○	○	○
Non Marking Tires	○	○	n/a
Catalytic Muffler	○	○	○
Battery Isolated Switch	○	○	○
Lockable Fuel Cap	○	○	○
Speedometer	○	○	○
Lockable Side Covers **	○	○	n/a
Lift and Tilt Locking	●	●	●
Full Free Triple Mast	n/a	n/a	○

\* : The cloth deluxe suspension seat is provided with optional operator cab  
\*\* : Lockable side covers are available on E.U country only

■ **Main Specification**

Sales Models		D110S-5	D130S-5	D160S-5
Rated Load Capacity	kg	11,000	13,000	16,000
Load Center	mm	600	600	600
Overall Width	W mm	2350	2350	2490
Overall Length to Fork Face	L mm	4340	4340	4715
Height to Overhead Guard	H mm	2765	2765	2928
Minimum Turning Radius	R mm	4040	4040	4400
Wheel Base	mm	2850	2850	3150
Travel Speed, Loaded	km/h	33.0	33.0	29.0
Lifting Speed, Loaded	mm/s	450	430	410
Engine Model		DL06	DL06	DL06
Engine Maker		Doosan	Doosan	Doosan
Rated Power of Engine	PS(HP)@rpm	140(138)@2100	140(138)@2100	160(158)@2100
Displacement of Engine	cc	5890	5890	5890
Number of Cylinder		6	6	6
Number of Speed(Fwd/Rev)		3 / 3	3 / 3	3 / 3